

PROJECT LOCATION

WAWONA ST. AND AIRPORT WAY
MANTECA, CA

PROJECT TEAM

PROJECT CONTACT:
ANGRAJ CHAHAL
1897 OLEANDER AVE
MANTECA, CA 95337
(209) 203-4696
kchahal5@gmail.com

ARCHITECT:
API
4335-B NORTH STAR WAY
MODESTO, CA 95356
(209) 577-4661
CONTACT: BRIAN ROSENBERGER
brian@apiarc.com

SITE DATA

ASSESSORS PARCEL NUMBER:	222-100-15, 222-100-14 & 222-100-09
PROPERTY AREA:	72,745 SQ. FT. / 1.67 AC
BUILDING COVERAGE (OF PROJECT AREA):	12,125 SQ. FT. (17%)
COMMUNITY OPEN SPACE (GROUND LEVEL):	+/-17,415 SQ. FT. (24%)
ROOF DECK COMMUNITY OPEN SPACE:	4,426 SQ. FT.
TOTAL COMMUNITY OPEN SPACE:	21,841 SQ. FT. (30%)
CURRENT ZONE:	CG / RE
PROPOSED ZONE:	R3
CURRENT GENERAL PLAN:	GC / VLDR
PROPOSED GENERAL PLAN:	HIGH DENSITY RESIDENTIAL
DENSITY:	26.3 DU/ACRE

BUILDING DATA

APARTMENT BUILDING DATA

BUILDING USE:	APARTMENTS
TYPE OF CONSTRUCTION:	VA
ALLOWABLE BUILDING HEIGHT:	60'-0"
MAXIMUM BUILDING HEIGHT:	59'-6"
ALLOWABLE NUMBER OF STORIES:	4
NUMBER OF STORIES:	4
ALLOWABLE BUILDING AREA:	36,000 S.F. / STORY
BUILDING AREA:	11,438 S.F. / STORY
TOTAL BUILDING AREA (APARTMENTS):	45,452 S.F.

APARTMENT BUILDING UNITS DATA

ONE BEDROOM UNITS:	20
TWO BEDROOM UNITS:	24
TOTAL UNITS:	44

PARKING DATA

PARKING REQUIRED

1 COVERED SPACE/ DWELLING UNIT + 1 SPACE/ 2 BEDROOM UNIT + 0.5 SPACE/ 1 BEDROOM UNIT	44 UNITS:	44 COVERED STALLS
	(24) 2 BEDROOM:	24 STALLS
	(20) 1 BEDROOM:	10 STALLS
TOTAL RESIDENTIAL PARKING REQUIRED:		78 STALLS

REQUIRED ACCESSIBLE RESIDENTIAL STALLS:	1 ASSIGNED STALL	2 UNASSIGNED STALLS
* (1) OF THESE (3) PARKING STALLS SHALL BE VAN ACCESSIBLE		

4 SPACES/1000 S.F. OF OFFICE	304 S.F. OFFICE =	2 STALLS
TOTAL PARKING REQUIRED FOR ENTIRE SITE:		80 STALLS

PARKING PROVIDED

COVERED STALLS:	44 STALLS
STANDARD:	2 STALLS (1 OF WHICH TO BE AN UNASSIGNED STALL)
ACCESSIBLE:	
UNCOVERED STALLS:	
STANDARD:	16 STALLS
COMPACT (21%):	17 STALLS
ACCESSIBLE:	2 STALL
TOTAL:	80 STALLS

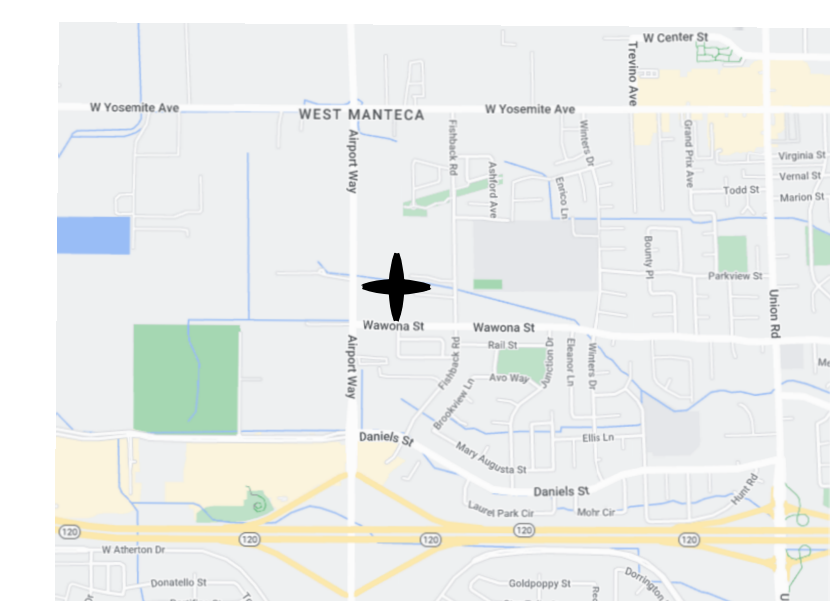

VICINITY MAP

WAWONA APARTMENTS

WAWONA AND AIRPORT WY
MANTECA, CA.

PLANNING ARCHITECTURE



ARCHITECTURE PLUS INC.
4335-B NORTH STAR WAY
MODESTO, CA 95356

ph. 209.577.4661
fx. 209.577.0213

www.apiarc.com

SHEET:

A1
OF 10

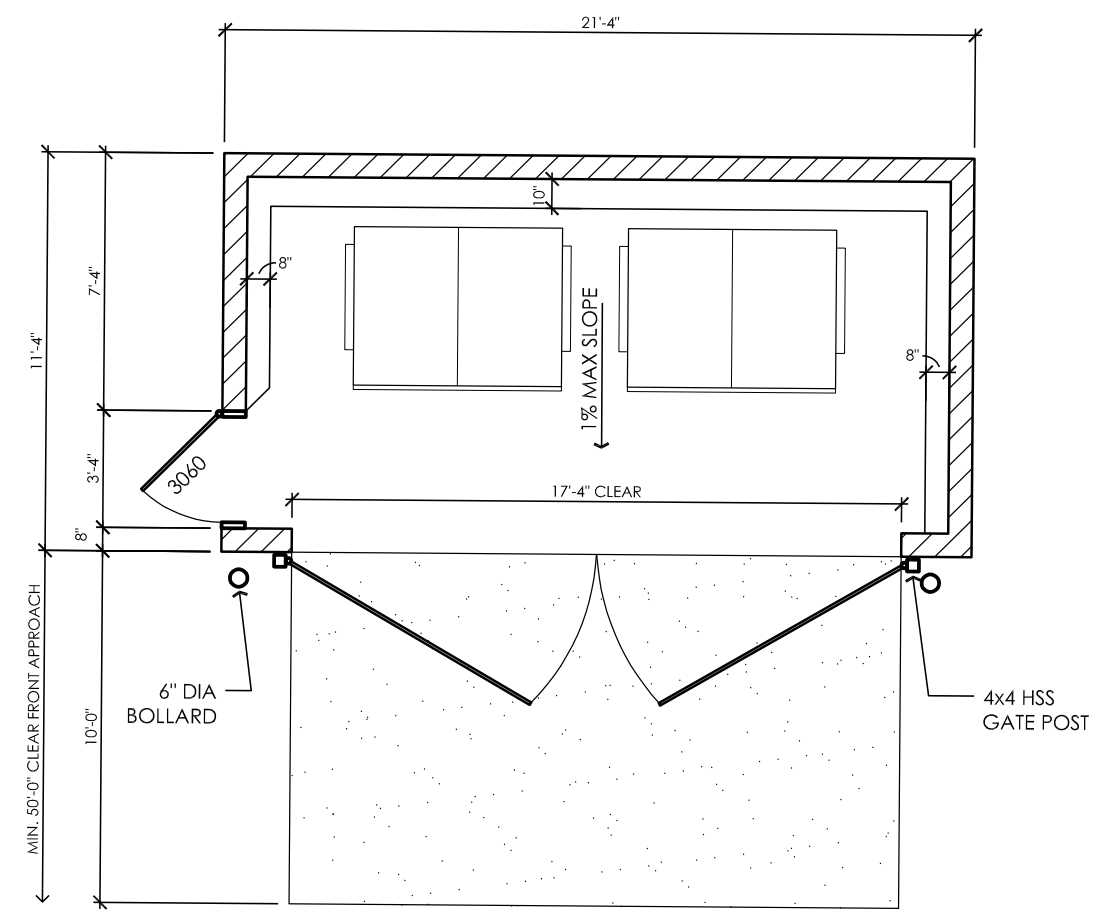
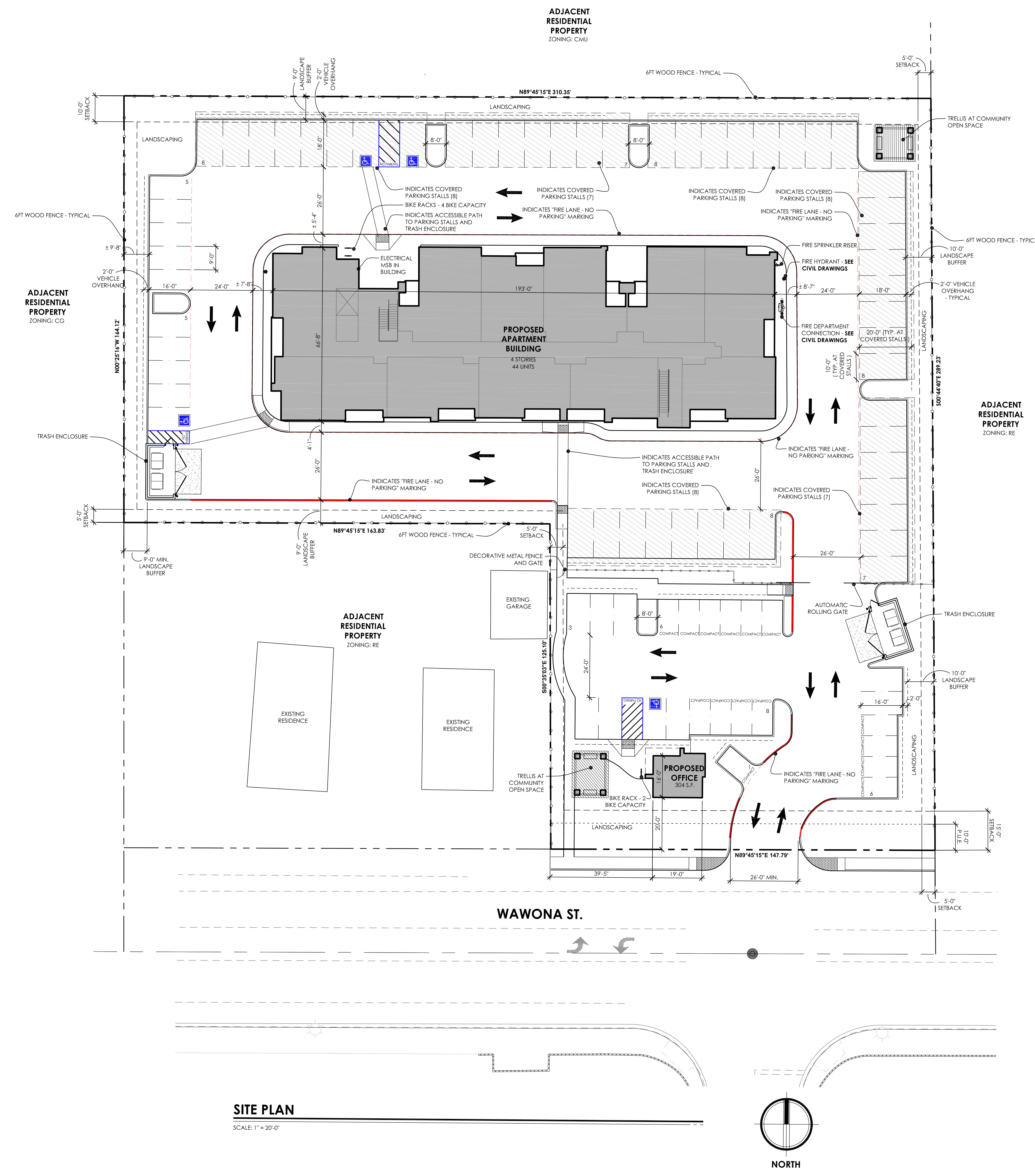

TRASH ENCLOSURE - FLOOR PLAN

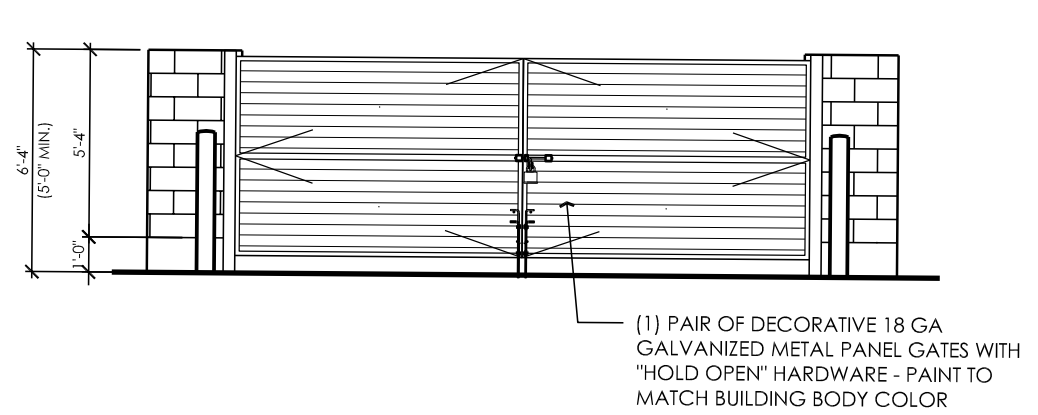

TRASH ENCLOSURE - FRONT ELEVATION

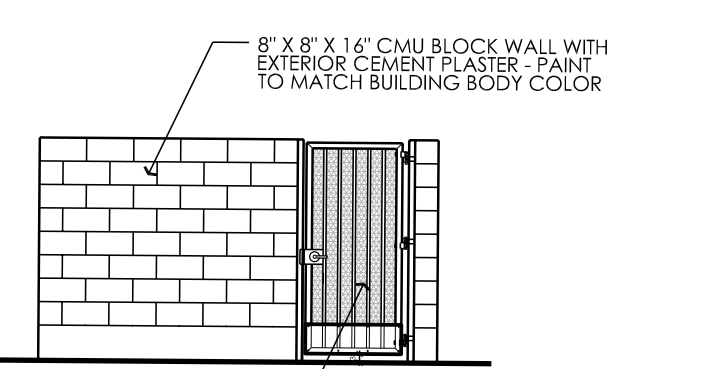

TRASH ENCLOSURE - SIDE ELEVATION

TRASH ENCLOSURE

SCALE: 3/16" = 1'-0"

SITE PLAN

SCALE: 1" = 20'-0"

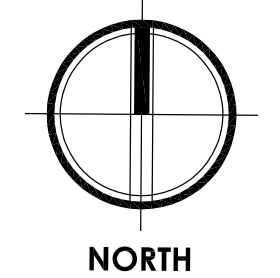

NOTE:
THIS CONCEPTUAL SITE PLAN WAS DEVELOPED WITH SITE BOUNDARY INFORMATION PROVIDED BY THE OWNER. API IS NOT RESPONSIBLE FOR THE ACCURACY OF THIS INFORMATION.

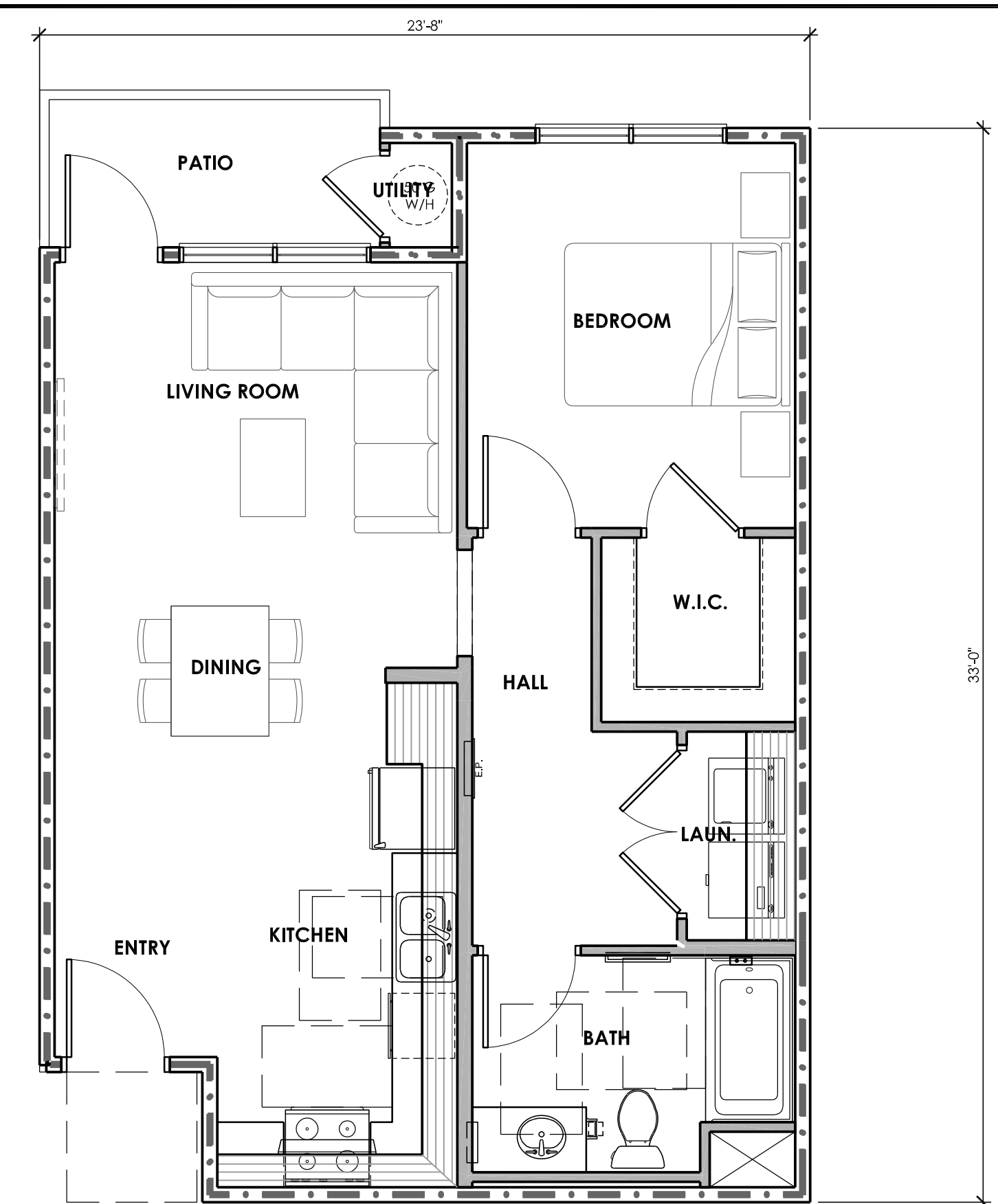

UNIT B FLOOR PLAN - ONE BEDROOM

SCALE: 1/4" = 1'-0"

FLOOR AREAS:	
CONDITIONED AREA	- 715 S.F.
UTILITY CLOSET	- 8 S.F.
COVERED PATIO	- 51 S.F.
TOTAL	- 774 S.F.

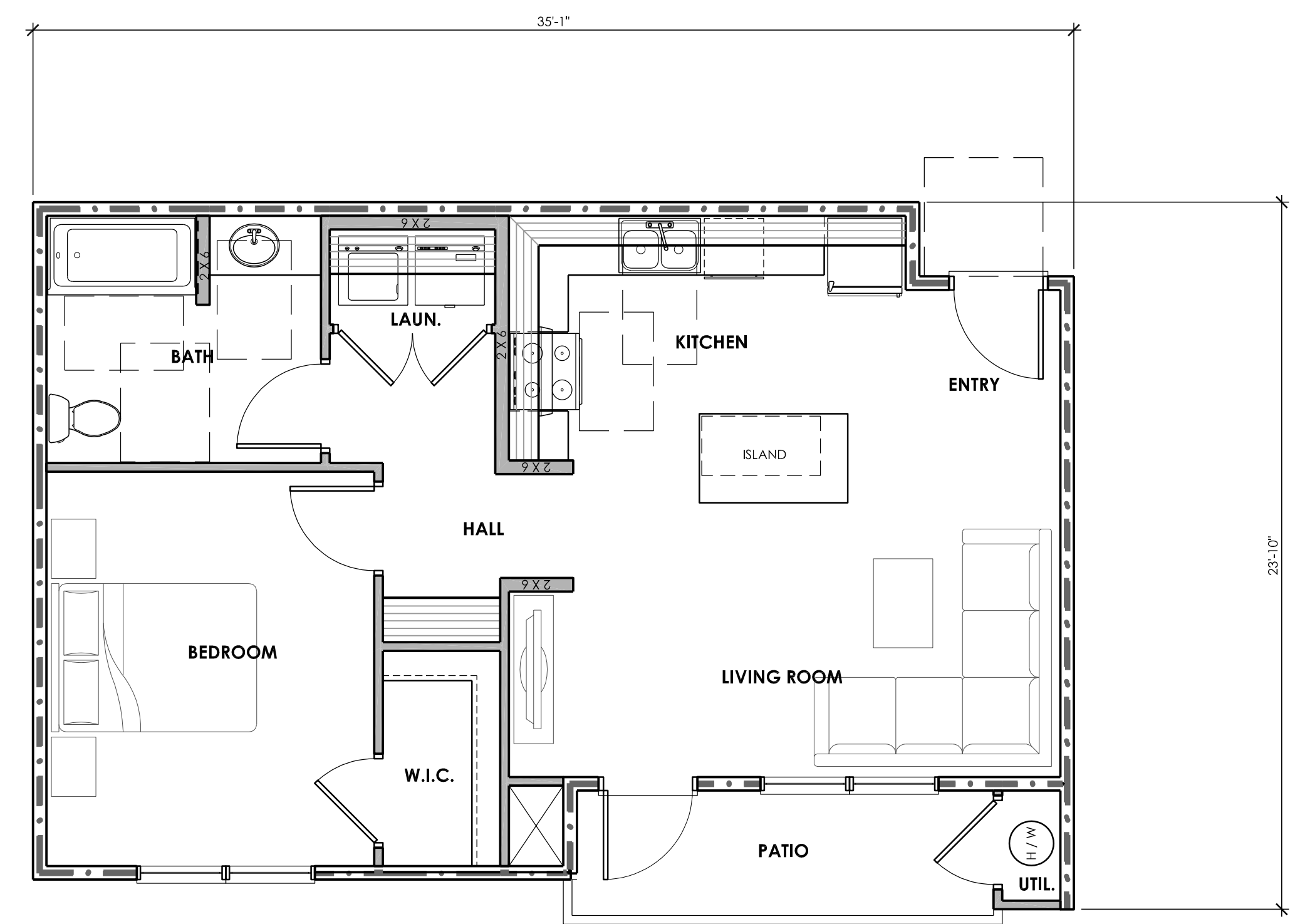

UNIT A FLOOR PLAN - ONE BEDROOM

SCALE: 1/4" = 1'-0"

FLOOR AREAS:	
CONDITIONED AREA	- 737 S.F.
UTILITY CLOSET	- 11 S.F.
COVERED PATIO	- 60 S.F.
TOTAL	- 834 S.F.

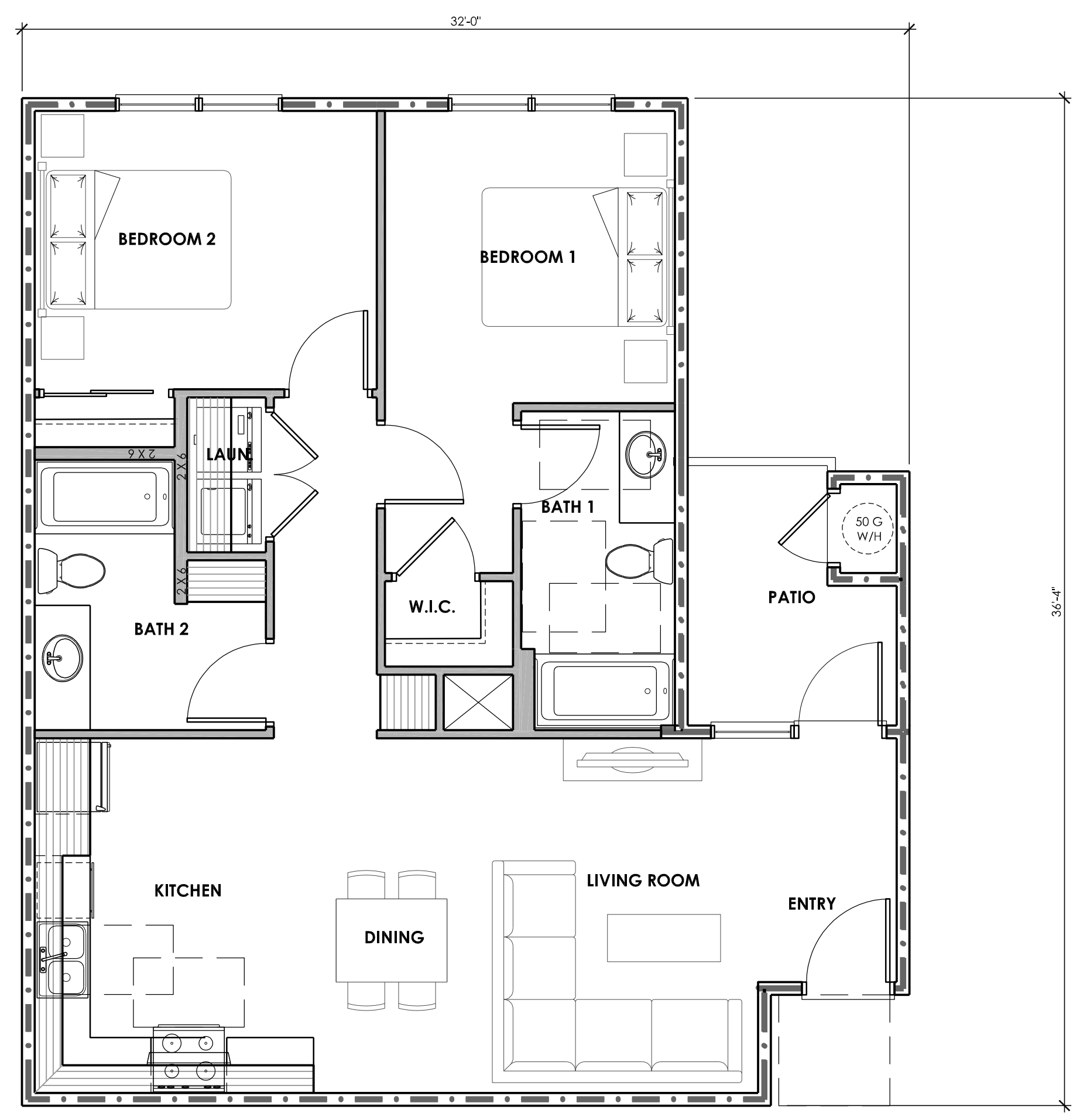

UNIT D FLOOR PLAN - TWO BEDROOM

SCALE: 1/4" = 1'-0"

FLOOR AREAS:	
CONDITIONED AREA	- 962 S.F.
UTILITY CLOSET	- 12 S.F.
COVERED PATIO	- 64 S.F.
TOTAL	- 1038 S.F.

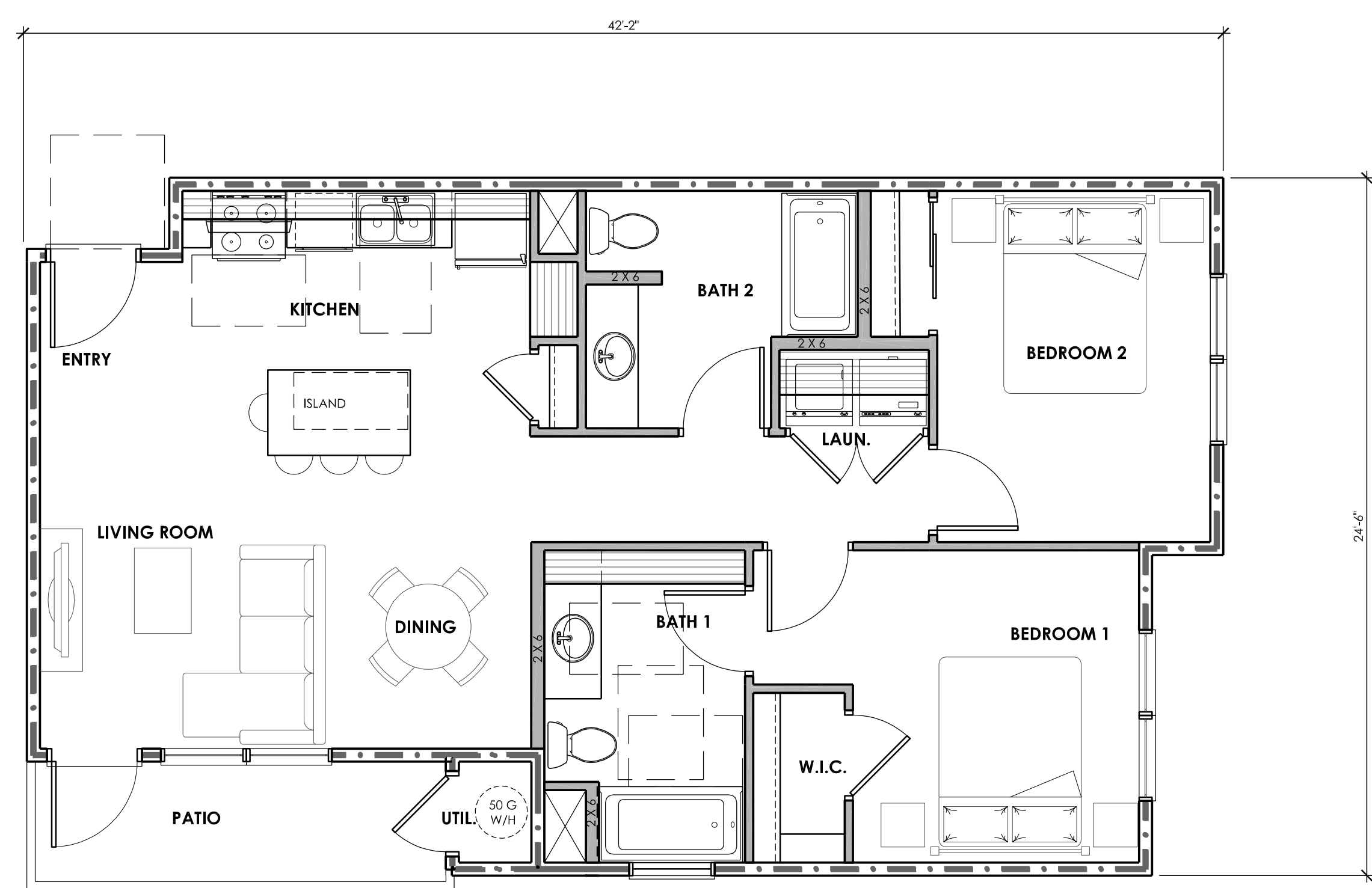

UNIT C FLOOR PLAN - TWO BEDROOM

SCALE: 1/4" = 1'-0"

FLOOR AREAS:	
CONDITIONED AREA	- 917 S.F.
UTILITY CLOSET	- 12 S.F.
COVERED PATIO	- 61 S.F.
TOTAL	- 990 S.F.

WAWONA APARTMENTS

WAWONA AND AIRPORT WY
MANTECA, CA.

PLANNING ARCHITECTURE



ARCHITECTURE PLUS INC.
4335-B NORTH STAR WAY
MODESTO, CA 95356

ph. 209.577.4661
fx. 209.577.0213

www.apiarc.com

SHEET:

A2
OF 10

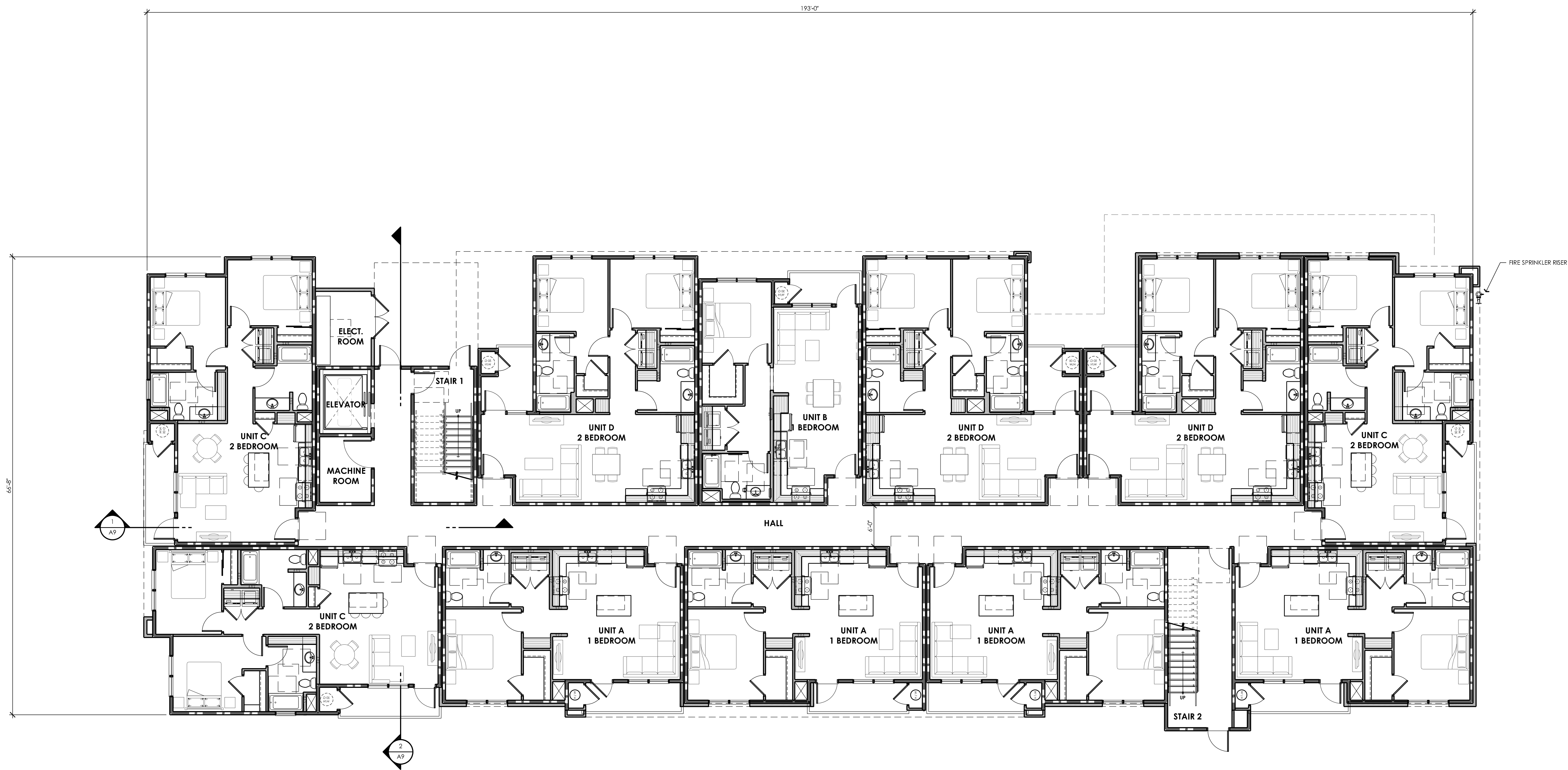

FIRST FLOOR PLAN

SCALE: 1/8" = 1'-0"



WAWONA APARTMENTS

WAWONA AND AIRPORT WY
MANTECA, CA.

PLANNING ARCHITECTURE



ARCHITECTURE PLUS INC.
4335-B NORTH STAR WAY
MODESTO, CA 95356

ph. 209.577.4661
fx. 209.577.0213

www.apiarc.com

SHEET:

A3

OF 10

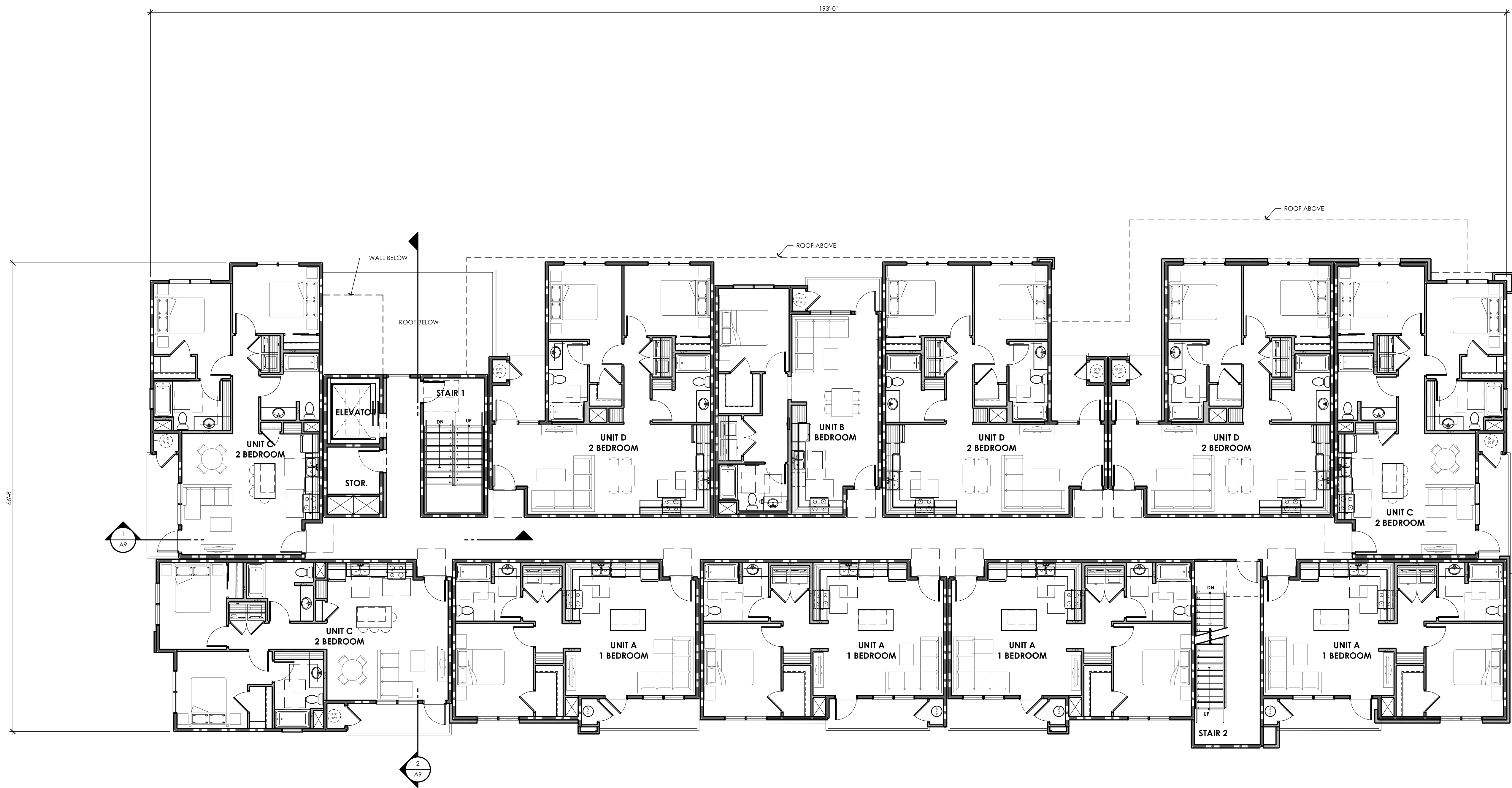

2ND, 3RD, & 4TH FLOOR PLANS

SCALE: 1/8" = 1'-0"

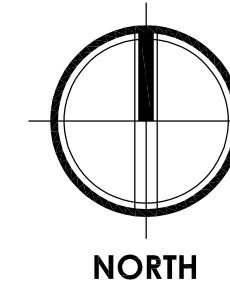

WAWONA APARTMENTS

WAWONA AND AIRPORT WY
MANTECA, CA.

PLANNING ARCHITECTURE



ARCHITECTURE PLUS INC.
4335-B NORTH STAR WAY
MODESTO, CA 95356

ph. 209.577.4661
fx. 209.577.0213

www.apiarc.com

SHEET:

A4

OF 10

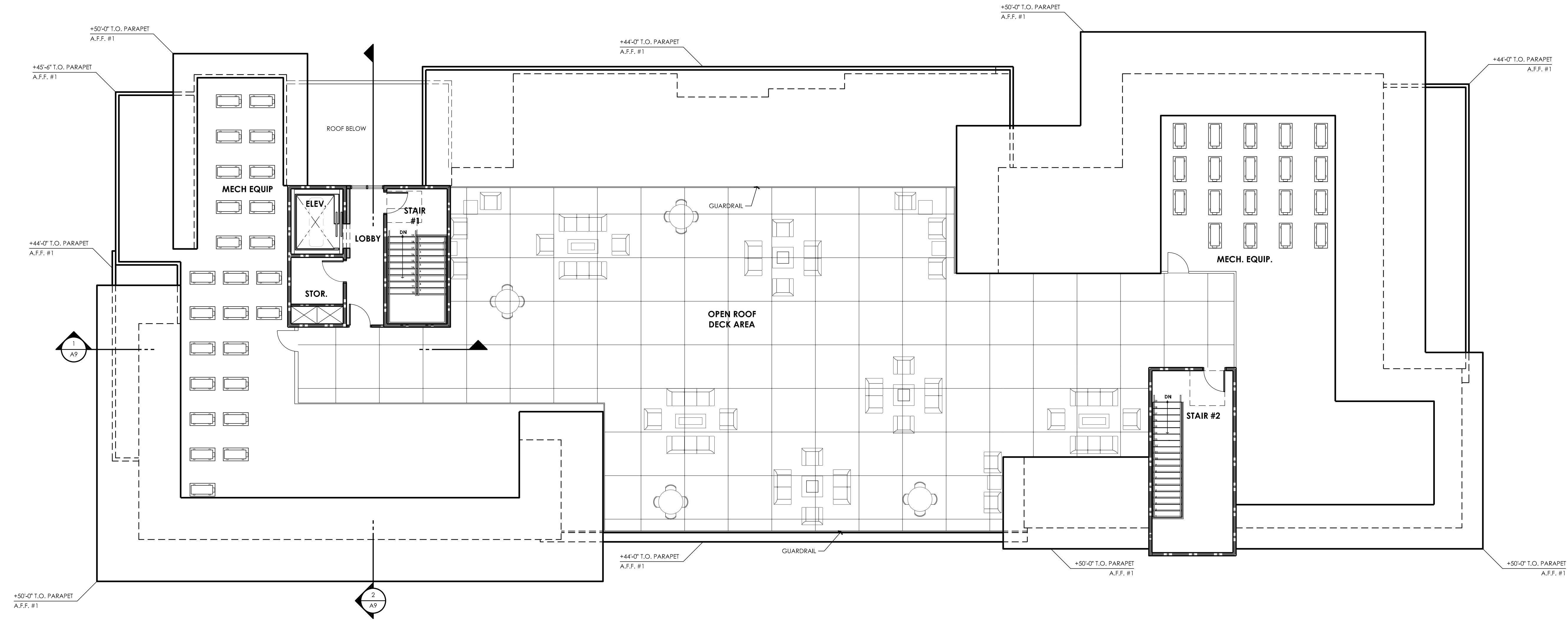

ROOF PLAN

SCALE: 1/8" = 1'-0"

WAWONA APARTMENTS

WAWONA AND AIRPORT WY
MANTECA, CA.

PLANNING ARCHITECTURE



ARCHITECTURE PLUS INC.
4335-B NORTH STAR WAY
MODESTO, CA 95356

ph. 209.577.4661
fx. 209.577.0213

www.apiarc.com

SHEET:

A5

OF 10

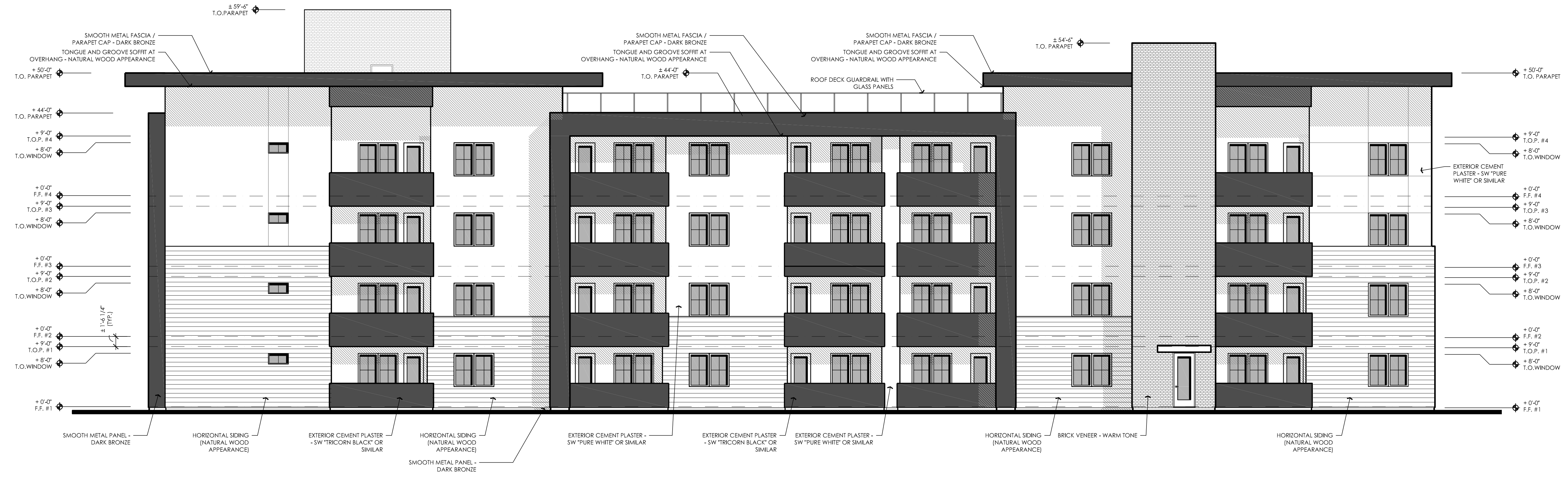

SOUTH ELEVATION

SCALE: 1/8" = 1'-0"



WEST ELEVATION

SCALE: 1/8" = 1'-0"

WAWONA APARTMENTS

WAWONA AND AIRPORT WY
MANTECA, CA.

PLANNING ARCHITECTURE



ARCHITECTURE PLUS INC.
4335-B NORTH STAR WAY
MODESTO, CA 95356

ph. 209.577.4661
fx. 209.577.0213

www.apiarc.com





SHEET:

A7
OF 10



NORTH ELEVATION

SCALE: 1/8" = 1'-0"

		
MAIN BODY COLOR: SHERWIN WILLIAMS "PURE WHITE" SW 7005	SECONDARY BODY COLOR: SHERWIN WILLIAMS "TRICORN BLACK" SW 6258	TERTIARY BODY COLOR: SHERWIN WILLIAMS "MORNING FOG" SW 6255
		
HORIZONTAL SIDING: NICHIHA SIDING "CEDAR"	BRICK VENEER: HC MUDDOX "SIERRA SLATE"	FLUSH METAL PANEL: AEP SPAN "MIDNIGHT BRONZE"



EAST ELEVATION

SCALE: 1/8" = 1'-0"

WAWONA APARTMENTS

WAWONA AND AIRPORT WY
MANTECA, CA.

PLANNING ARCHITECTURE



ARCHITECTURE PLUS INC.
4335-B NORTH STAR WAY
MODESTO, CA 95356

ph. 209.577.4661
fx. 209.577.0213

www.apiarc.com

SHEET:

A8

OF 10

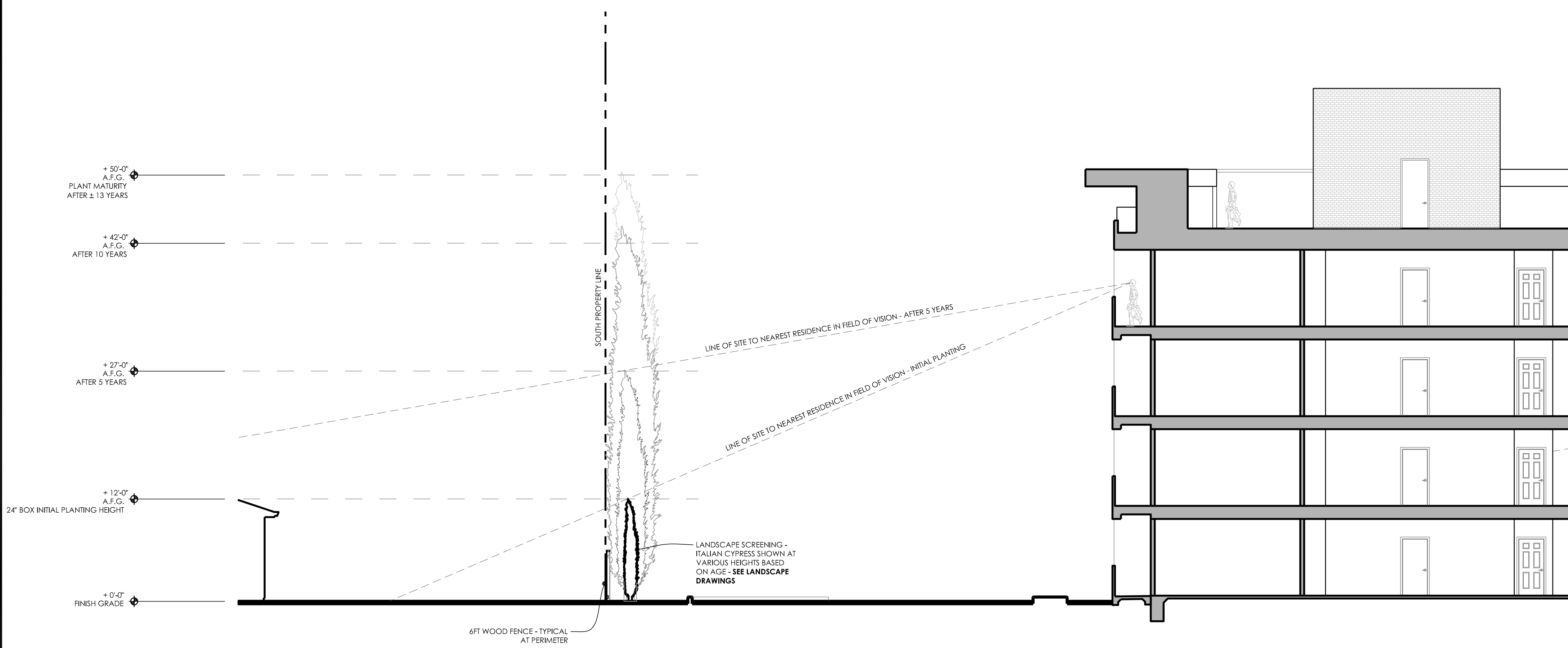

1 LINE OF SIGHT SECTION - VIEW TO SOUTH-WEST PROPERTY LINE
SCALE: 1/8" = 1'-0"

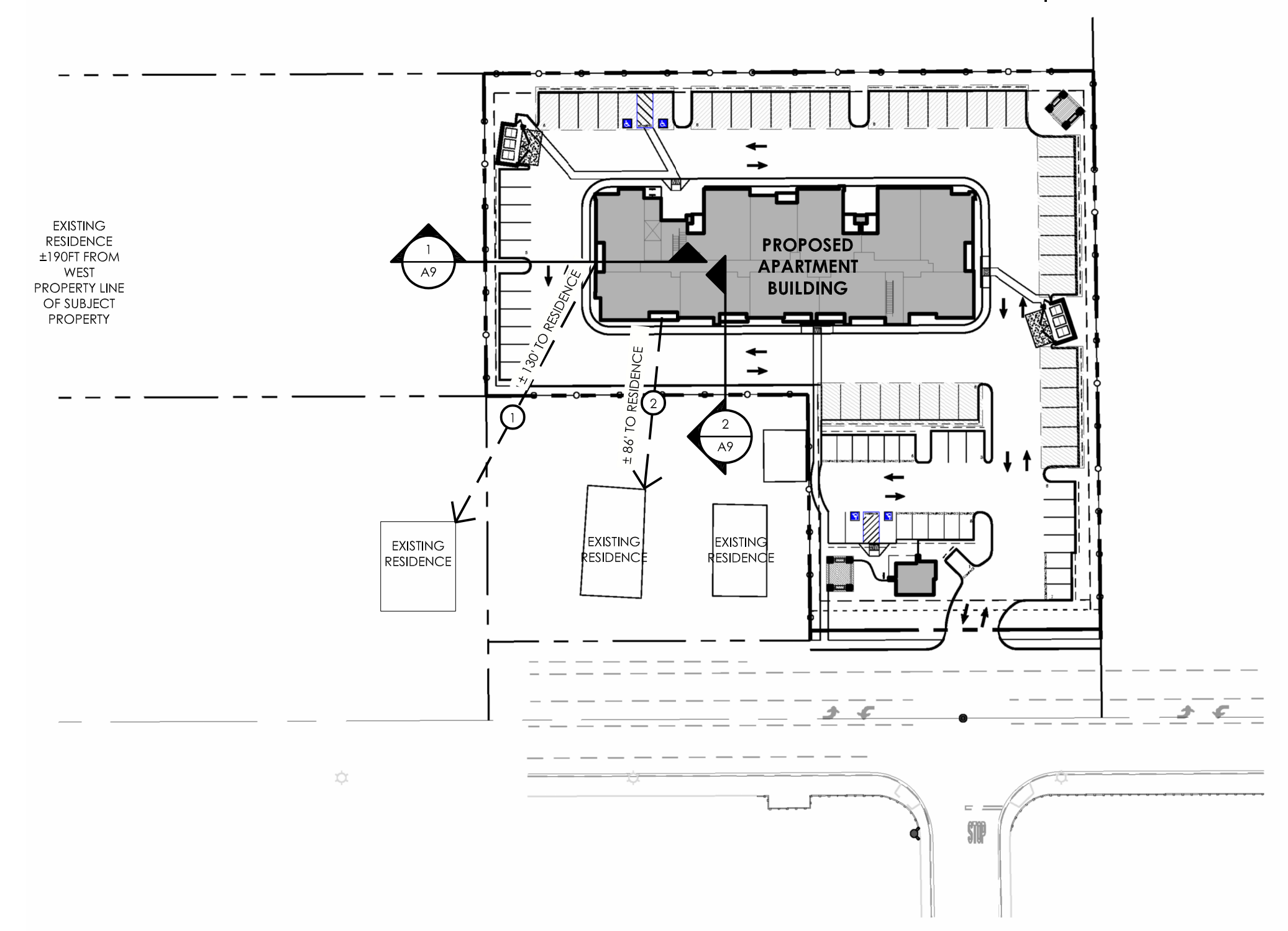

LINE OF SIGHT KEY MAP
SCALE: 1" = 60'-0"
NORTH

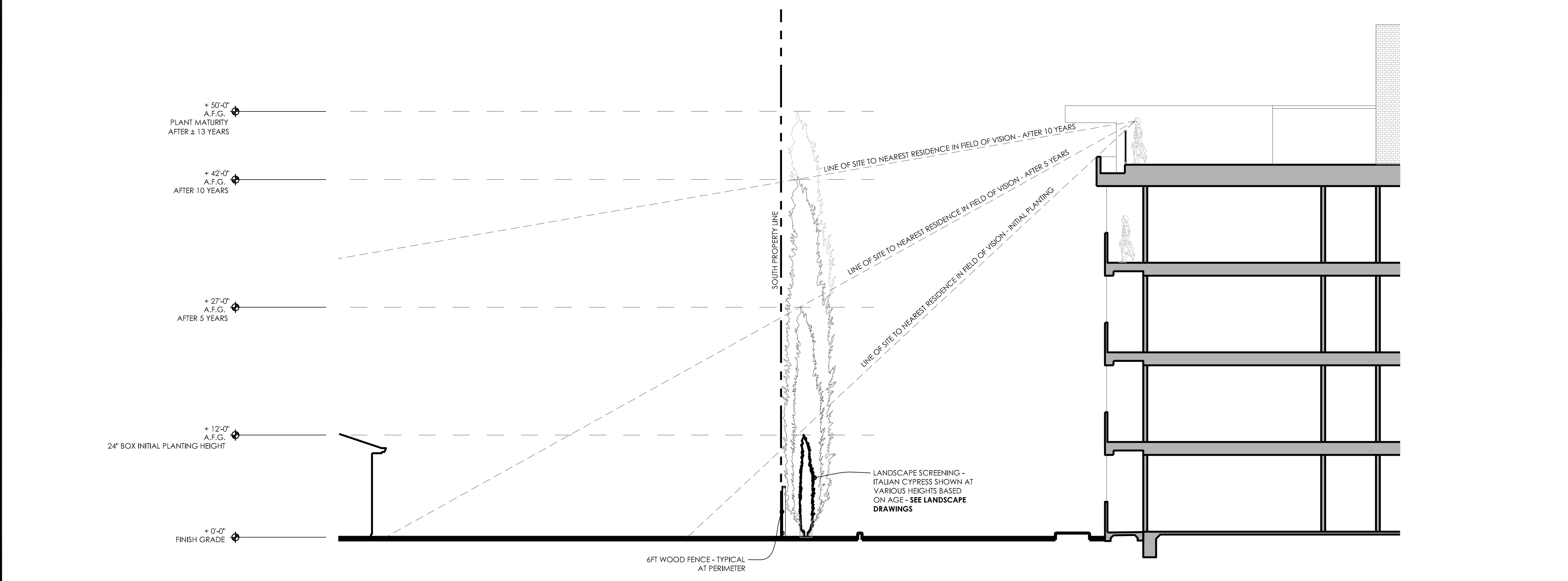

2 LINE OF SIGHT SECTION - VIEW TO SOUTH PROPERTY LINE
SCALE: 1/8" = 1'-0"

WAWONA APARTMENTS

WAWONA AND AIRPORT WY
MANTECA, CA.

PLANNING ARCHITECTURE



ARCHITECTURE PLUS INC.
4335-B NORTH STAR WAY
MODESTO, CA 95356

ph. 209.577.4661
fx. 209.577.0213

www.apiarc.com

SHEET:

A9
OF 10

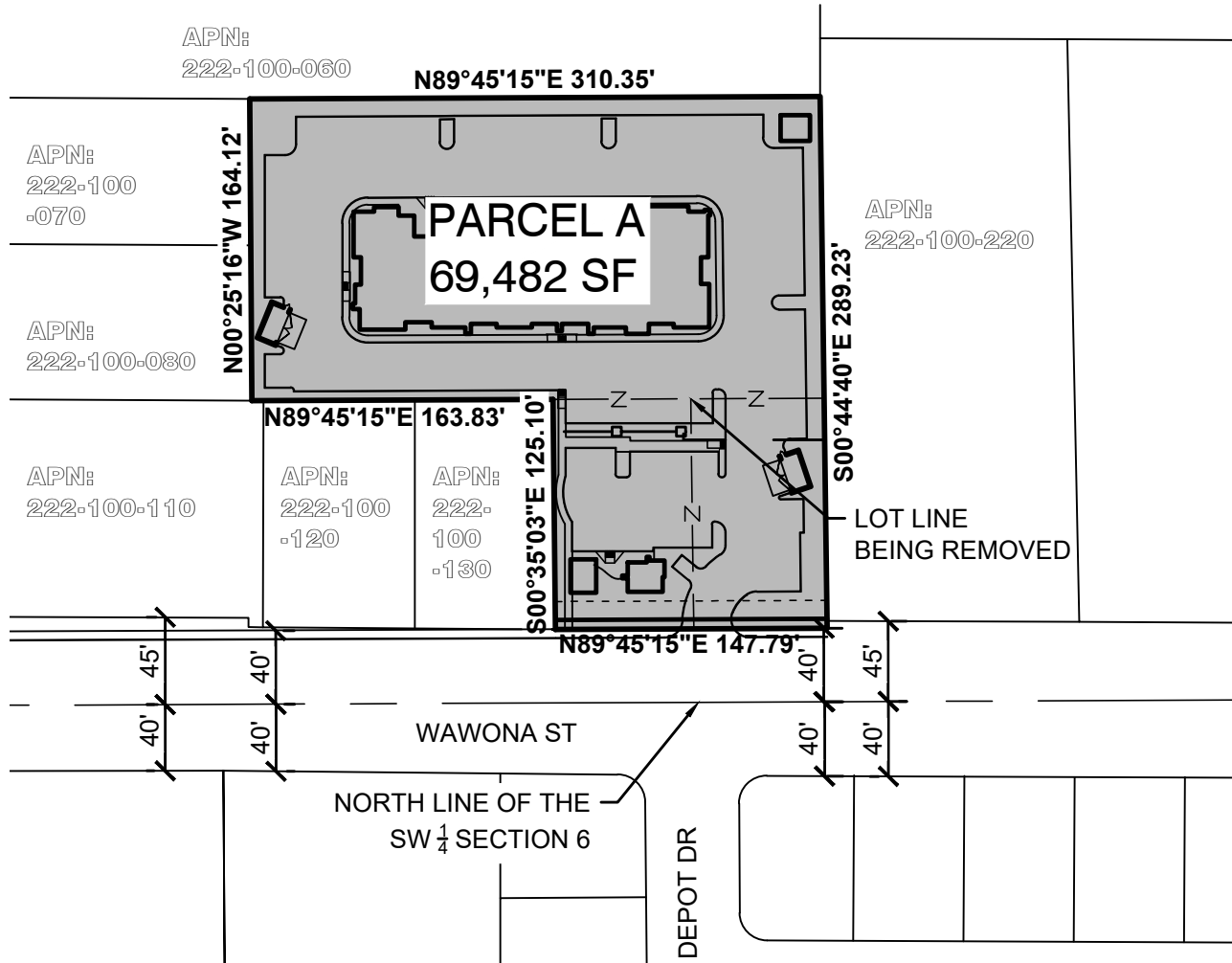

PROPOSED LOT LINE MERGER

WAWONA APARTMENTS

MANTECA, CA

DATE: 9/30/2024



MCR ENGINEERING
 www.mcreng.com
 MCR ENGINEERING, INC.
 1242 DUPONT COURT
 MANTECA, CA 95336
 TEL : (209) 239-6229
 FAX : (209) 239-8839